

**VOLVO  
PENTA**

# GENUINE VOLVO PENTA PROPELLERS

Features, benefits and specifications

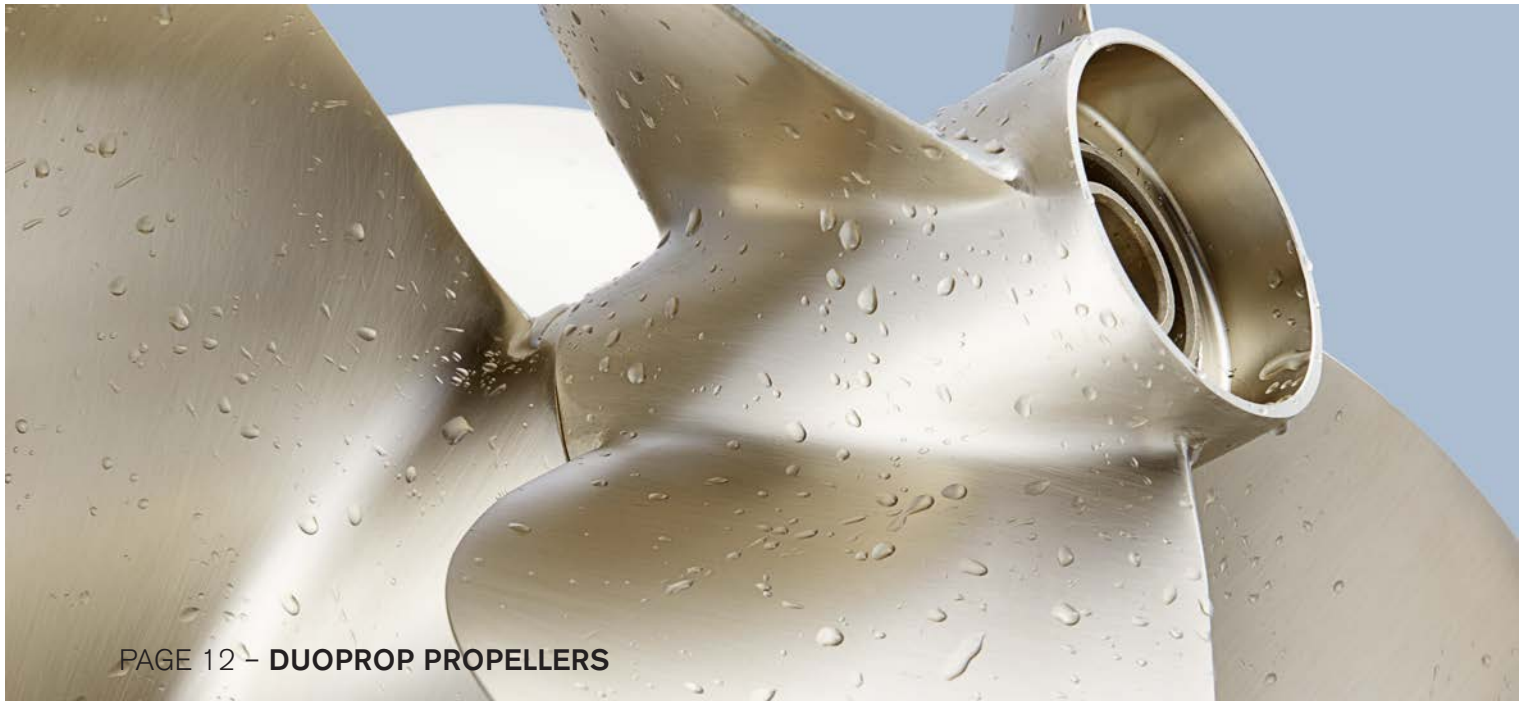



PAGE 12 – DUOPROP PROPELLERS

**CONTENTS**

**4 SINGLE PROPELLERS FOR AQUAMATIC STERNDRIVES**

- 6 SX
- 8 200-290, SP
- 10 100

**12 DUOPROP PROPELLERS FOR AQUAMATIC STERNDRIVES**

- 14 DPS
- 16 DPH
- 17 FWD
- 18 DPR
- 19 DPX
- 20 280, 290, DP

**22 PROPELLERS FOR VOLVO PENTA IPS**

- 24 IPS 1
- 25 IPS 15
- 26 IPS 2
- 27 IPS 3

**30 PROPELLERS FOR S-DRIVES AND SHAFTS**

- 31 FOLDING PROPELLERS
- 36 FIXED PROPELLERS

**38 RELATED PRODUCTS**

- 38 ANODES FOR DRIVES AND PROPELLERS
- 40 LINE CUTTER FOR IPS
- 41 GREASE FOR PROPELLER COMPONENTS

**Note!** For installation instructions, refer to the operators manual and additional information when it is supplied with the propeller or hardware. Read the instructions and safety information carefully before starting work. The illustrations in this publication are for illustrative purposes only.



PAGE 4 – SINGLE PROPELLERS



PAGE 22 – IPS PROPELLERS



PAGE 31 – FOLDING PROPELLERS

# The art of performance

Volvo Penta propellers are an engineering art form. Behind the slightest curve, smoothest contour and tightest angle is a state-of-the-art design process based on years of experience.

We know propellers. And what is more, we know how to convert the power of your driveline into real performance that you can feel on the water. It is this performance that leads to greater boating pleasure and at the same time contributes to the long-term health of your driveline.

## A wide range of experience

Aquamatic Sterndrive, Saildrive, Volvo Penta IPS and Forward Drive are among the greatest inventions to ever grace the marine industry – advanced and innovative engineering that can only come from extensive experience and an unwavering commitment to delivering greater boating pleasure. Our propellers are no exception. They are, and have always been, a vital part of this innovative process and have an integral role in changing the definition of performance, comfort and driving pleasure.

## The only way forward

For Volvo Penta, propellers will always be designed as a part of a complete propulsion system. It's the only way. Whether you have a powerboat or sailboat, there is a genuine Volvo Penta propeller, that has been completely designed for your needs.

**NEW**

Type N/NS for the new IPS 15  
See page 25.



## Double your warranty

Genuine Volvo Penta propellers are covered by our standard 12 month warranty. Have them supplied and installed by an authorized Volvo Penta dealer and we'll extend your warranty to 24 months — including the labor. Consult your nearest dealer for more details.



## Find your dealer

Your Volvo Penta dealer can help you identify the correct propeller for your driveline. Go to [volvopenta.com/dealerlocator](http://volvopenta.com/dealerlocator) to search among our 3,500 dealers worldwide. You can also download our app – Volvo Penta Dealer Locator.





## Single propellers for Aquamatic sterndrives

# Fifty years of performance

Volvo Penta launched the first single propeller sterndrive over half a century ago. A lot has changed since 1959. The march of technology continues, but one factor remains the same – real performance comes from a propeller and driveline that are perfectly matched.

Genuine Volvo Penta single propellers for Aquamatic Sterndrives must be developed exclusively for their drive, matching both engine power and torque.

The result is a proven design that ensures optimal performance, fuel economy and comfort along with the peace of mind you expect from Volvo Penta.

**Precise balancing** gives minimal vibrations, quiet and comfortable operation. It is also essential for efficiency and minimizes wear on the drivetrain.

**Shock-absorbing** rubber bushing in the hub reduces turning and pulling forces and minimizes stress on the drivetrain caused by gear changes and propeller impact.

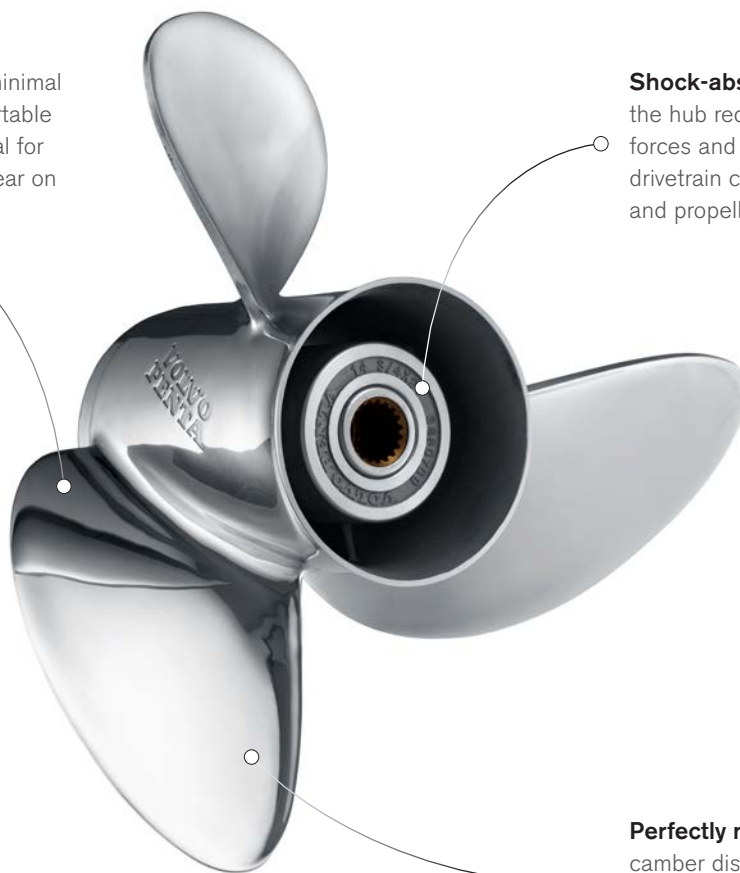

**Developed and tested** to ensure optimal performance, durability, fuel efficiency and life expectancy.

**Perfectly matched** pitch and camber distribution contributes to excellent propeller grip, optimal operational efficiency, safe and predictable handling.



# SX Drives

## 3-blade aluminum propeller

With its wide and efficient blade design this propeller offers excellent acceleration and top speed. The state-of-the-art squeeze casting process together with special high-strength aluminum alloy makes it stronger and more durable than traditional die-cast propellers. Four layers of paint ensure excellent anti-corrosion performance.

- Strong and durable high-performance 3-blade aluminum propeller.
- Wide and efficient blade design providing excellent acceleration and top speed.
- Shock-absorbing rubber bushing reduces vibrations and stress on the drivetrain.
- Four layers of paint ensure excellent anti-corrosion performance.



Ø x PITCH	 LH	 RH
14.3 x 21	-	3817469
14.2 x 23	-	3817470
14.5 x 19	3817473	3817468
14.8 x 17	3817472	3817467
15 x 15	3817471	3817466
15 x 16	-	-
15.5 x 12	3855476	-
15.5 x 13	3855477	3840720
15.5 x 14	3855478	-



Installation hardware, see next page.

## 4-blade aluminum propeller

The four-blade propeller features the same strength and durability as the three-blade propeller. Four blades provide increased torque for heavy loads and maneuverability together with great stern lifting and mid-range performance. Four layers of paint ensure excellent anti-corrosion performance.

- Strong and durable high-performance 4-blade aluminum propeller.
- Increased thrust for heavy loads and maneuverability.
- Shock-absorbing rubber bushing reduces vibrations and stress on the drivetrain.
- Four layers of paint ensure excellent anti-corrosion performance.



Ø x PITCH	 LH	 RH
14.75 x 15	3587519	3587517
14.5 x 17	3587521	3587520
14.25 x 19	3587523	3587522
14 x 21	3587525	3587524
14 x 23	3587527	3587526

Installation hardware, see next page.



# SX Drives

## 3-blade stainless steel propeller

This performance provider enhances top speed, acceleration and durability versus a comparable aluminum propeller. The blade configuration and through-hub exhaust design are important factors for high efficiency and performance. This high-strength stainless steel propeller really push the limits and makes it a perfect choice for high-power engines and fast boats.

- Enhances acceleration and top speed versus a comparable aluminum propeller.
- Excellent strength, durability and corrosion resistance.
- Shock-absorbing rubber bushing reduces vibrations and stress on the drivetrain.



Ø x PITCH	 LH	 RH
14.75 x 17	3860714	3862462
14.75 x 19	3860715	3860708
14.75 x 21	3860716	3860709
14.25 x 23	3860717	3860710

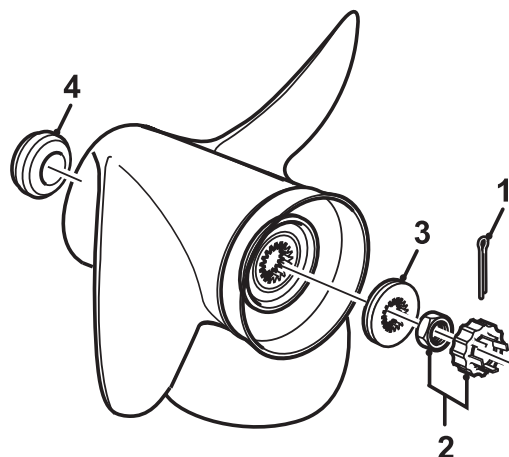

## Installation hardware, 3 and 4-blade propellers for the SX drive

Pos	Part No	Item
1	3852056	Split pin
2	3850984	Propeller nut

Pos	Part No	Item
3	3852350	Spacer
4	3852020	Thrust washer

# 200, 250, 270, 275, 280, 285, 290, SP Drives



## Aluminum propeller with long hub - High-speed series

The High-speed propeller with long hub is developed from the standard propeller and features more blade area. In a fast boat this not only means increased speed, but also that a heavily loaded boat will plane more quickly and enjoy better fuel economy. The increased blade area also provides faster and safer quayside maneuvering.

- Made of durable aluminum alloy developed to withstand salt water and cavitation damage.
- Painted with epoxy powder - extremely hard and resistant to abrasion.
- Long hub design with shock-absorbing rubber bushing.



**Note!** Always use long hub propeller for V6, V8, AQD40, AQAD31/40/41 engines.

Ø x PITCH	 LH	 RH
14 x 17	854977	854992
14 x 19	854978	854993
14 x 21	854979	854994
14 x 23	854980	854995
15 x 15	854981	854996
15 x 17	854982	854997
15 x 19	854983	854998
15 x 21	854984	854999
16 x 9	854985	—
16 x 13	854986	872000
16 x 15	854987	872001
16 x 17	854988	872002
16 x 19	854989	872003
16 x 21	854990	872004
16 x 23	854991	872005

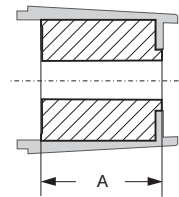

Long hub bushing  
A = 93mm (3.661")

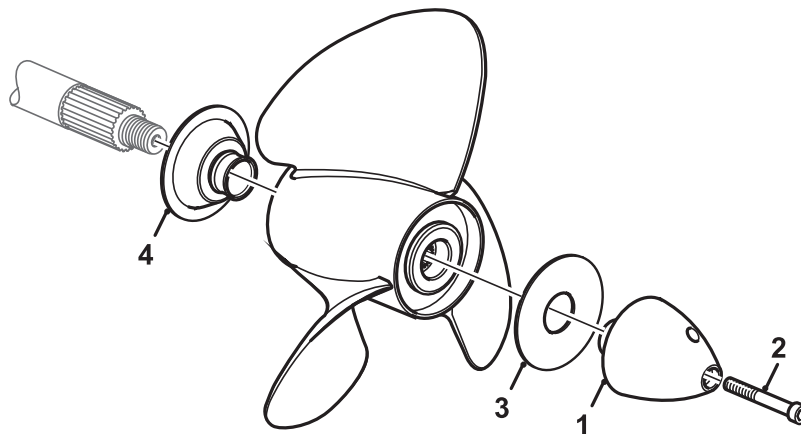

## Installation hardware, long hub propeller

The propeller cone locking requires that the drive has an internally threaded propeller shaft intended for the locking screw (2), which was introduced on late production 270 and 280 drives but included as standard on newer drives. In some cases, older drives have been updated using retrofit drilling and threading.

Pos	Part No	Item
1	854045	Propeller cone
2	850889	Locking screw
3	850888	Plastic washer
4	832965	Line cutter / Thrust washer, 200

Pos	Part No	Item
4	839534	Line cutter / Thrust washer, 250, 270, 275
4	839423	Line cutter / Thrust washer, 280, 285, 290, SP-A
4	872082	Line cutter / Thrust washer, SP-A1, A2, C, C1, E
	873058	Tool



# 200, 250, 270, 275, 280, 285, 290, SP Drives



## Aluminum propeller with short hub – High-speed and standard series

The High-speed propeller features more blade area than the standard propeller. In a fast boat this does not only mean increased speed, it also means that a heavily loaded boat will plane more quickly, enjoying better fuel economy and increased cruising speed. The increased blade area also provides faster and safer quayside maneuvering.

- Made of durable aluminum alloy developed to withstand salt water and cavitation damage.
- Painted with epoxy powder – extremely hard and resistant to abrasion.
- Short hub design with shock-absorbing rubber bushing.



**Note!** Always use long hub propeller for V6, V8, AQD40, AQAD31/40/41 engines.

Ø x PITCH	 LH	 RH
14 x 13	813284 STD	813285 STD
14 x 15	814626 HS	814631 HS
14 x 17	814627 HS	814632 HS
14 x 19	814628 HS	814633 HS
15 x 11	813296 STD	813297 STD
15 x 13	813316 STD	813317 STD
15 x 15	814611 HS	814615 HS
15 x 17	814612 HS	814616 HS

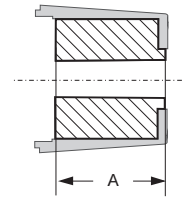

Short hub bushing  
A = 78mm (3.071")

HS = High-speed propeller, short hub

STD = Standard propeller, short hub

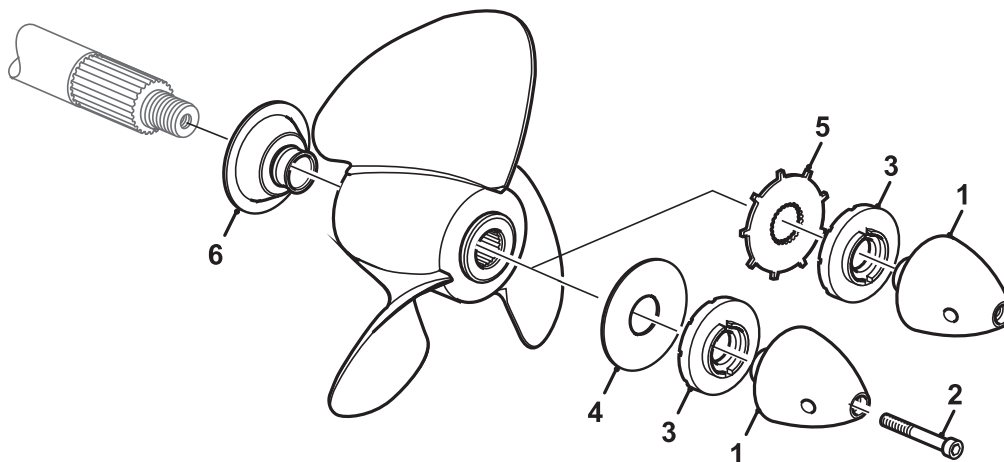

## Installation hardware, short-hub propeller

The propeller cone is locked in different ways depending on the propeller shaft design. Use the locking screw (2) on newer drives that use an internally threaded propeller shaft. On drives without an internally threaded propeller shaft, use the tab washer (5).

Pos	Part No	Item
1	854045	Propeller cone
2	850889	Locking screw
3	854047	Spacer ring
4	850888	Plastic washer
5	897367	Tab washer

Pos	Part No	Item
6	832965	Line cutter / Thrust washer, 200
6	839534	Line cutter / Thrust washer, 250, 270, 275
6	839423	Line cutter / Thrust washer, 280, 285, 290, SP-A
6	872082	Line cutter / Thrust washer, SP-A1, A2, C, C1, E
	873058	Tool



# 100 Drives

## Aluminum propeller – Standard and High-speed series

Standard and High-speed propellers are made from a special, durable aluminum alloy developed to withstand salt water and cavitation damage. Painted black with a special epoxy powder which is extremely hard and resistant to abrasion, the High-speed propeller features more blade area for increased performance.





### Propellers for 100 drives with cylindrical shaft and locking pin

Ø x PITCH	 LH	 RH
13 x 13	813224 STD	813233 STD
13 x 15	839186 HS	
14 x 11	813227 STD	
14 x 13	813229 STD	
14 x 15	832992 STD	

HS = High-speed propeller      STD = Standard propeller

### Propellers for 100 drives with splines (13/16")

Ø x PITCH	 LH	 RH
14 x 11	804449	—

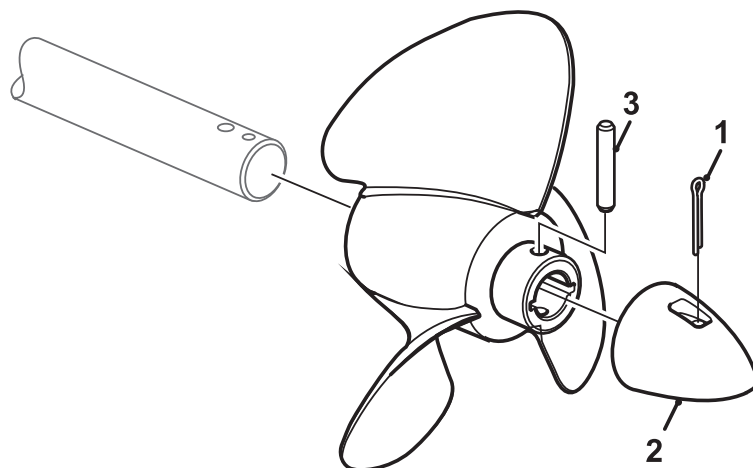

### Installation hardware, 100 drives with cylindrical shaft and locking pin

Pos	Part No	Item
1	907881	Split pin
2	806660	Propeller cone

Pos	Part No	Item
3	806661	Shear pin



## Anodes for drives and propellers

Genuine Volvo Penta anodes are specially designed, manufactured and tested to ensure a perfect fit, ensuring reliable fastening and optimal anode protection for Volvo Penta drives and propellers.

Learn more on page 38







## Duoprop propellers for Aquamatic Sterndrives

# Two propellers. One superior thrust.

Launched in 1982, Volvo Penta showed the marine industry that twin counter-rotating propellers could produce unparalleled thrust, straight and true tracking along with faster acceleration – a completely new boating experience.

The duoprop propellers are designed to form a vital part of the driveline, providing highly efficient and predictable handling, together with excellent onboard comfort and fuel efficiency.

Every set of duoprop propellers is designed, tested and manufactured together to ensure not only a high top speed, but the best overall performance – all this while securing the service life of your drive.

**Optimal interaction** between the front and rear propeller ensures maximum performance and fuel efficiency throughout the entire speed range, as well as smooth and comfortable running.

**Perfectly matched** pitch and camber distribution contributes to excellent propeller grip, optimal operational efficiency, safe and predictable handling.

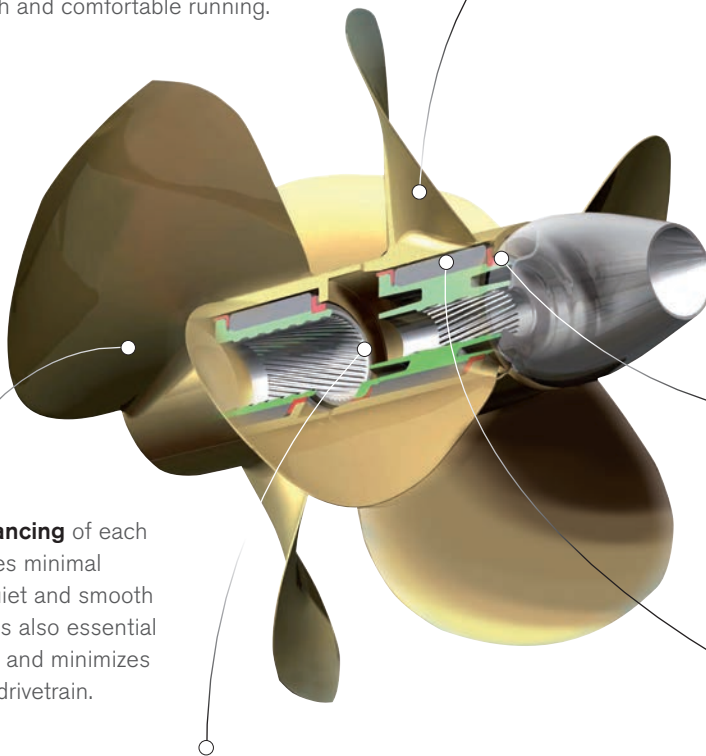

**Precise balancing** of each propeller gives minimal vibrations, quiet and smooth operation. It is also essential for efficiency and minimizes wear on the drivetrain.

**Optimized torque distribution** between front and rear propellers ensures that the drive works with the load it is designed for – essential in preserving the life of the drivetrain.

**Propellers made of stainless steel or nickel-bronze-aluminum also include:**

**Galvanic isolation** - the propeller bushing is designed to galvanically isolate the propeller from the drive. It will greatly reduce anode consumption and prevent galvanic corrosion that could be caused by the propeller.

**Shock-absorbing** rubber bushing in the hub reduces vibration, turning and pulling forces and minimizes stress on the drivetrain caused by gear-changes and propeller impact.



# DPS Drives

## Type I and IH - Aluminum Duoprop propellers

The patented blade geometry and large active propeller diameter provide optimal performance and fuel efficiency over the entire speed range as well as smooth running, excellent grip and maneuverability. Squeeze casting and special high-strength aluminum alloy makes them stronger and more durable than traditional die-cast propellers. Four layers of paint ensure excellent anti-corrosion performance. Type I has straight splines, type IH has helical splines.



- Engineered to optimize performance, durability and comfort.
- Patented blade geometry, large active propeller diameter.
- Strong and durable high-strength aluminum alloy.
- Three-blade front propeller and four-blade rear propeller.

**Note!** Always use type F or FH stainless steel propellers in engines exceeding 240 hp or capable of speeds above 38 knots (45 mph). See next page.

### Type I for DPS, DPS-A (straight splines)

DIM	Set	Front	Rear	DIM	Set	Front	Rear
I 2	21258482	21260642	21657162	I 7	21258487	21260647	21657167
I 3	21258483	21260643	21657163	I 8	21258488	21260648	21657168
I 4	21258484	21260644	21657164	I 9	21258489	21260649	21657169
I 5	21258485	21260645	21657165	I 10	21258490	21260650	21657170
I 6	21258486	21260646	21657166				

Installation hardware, see next page.

### Type IH for DPS-B (helical/spiral splines)

DIM	Set	Front	Rear	DIM	Set	Front	Rear
IH 2	21661942	21661902	21661922	IH 7	21661947	21661907	21661927
IH 3	21661943	21661903	21661923	IH 8	21661948	21661908	21661928
IH 4	21661944	21661904	21661924	IH 9	21661949	21661909	21661929
IH 5	21661945	21661905	21661925	IH 10	21661950	21661910	21661930
IH 6	21661946	21661906	21661926				

Installation hardware, see next page.

### Upgrade from type D propellers to type I propellers

To ensure the best performance for your boat, consult your Volvo Penta dealer for advice on the right propeller size for your drive and engine.

**Note!** Do not mix Type D and I propellers. Always use propellers of the same type and size on the drive (or on both drives in twin installations).

### Type D - Aluminum Duoprop propellers for DPS, DPS-A (straight splines)

Type D propeller sets are replaced by type I propeller sets. However, Type D propellers (front and rear) are sold individually as spare parts.

DIM	Front	Rear	DIM	Front	Rear
D 0	3851420	3851440	D 4	3851424	3851444
D 1	3851421	3851441	D 5	3856345	3856355
D 2	3851422	3851442	D 6	3856346	3856356
D 3	3851423	3851443	D 7	3856347	3856357

Installation hardware, see next page.



# DPS Drives

## Type F and FH – Stainless-steel Duoprop propellers

This is the perfect upgrade for enhanced performance, strength and durability. It provides better acceleration and higher top speed due to greater strength and thinner blades - versus a comparable aluminum propeller. The high-strength stainless steel adds excellent durability and corrosion resistance. Complete with shock-absorbing rubber bushing and galvanic isolation makes it perfectly matched for the DPS-drive and the ultimate choice for demanding boaters.



- Enhanced acceleration and top speed versus a comparable aluminum propeller.
- Excellent strength, durability and corrosion resistance.
- Galvanic isolation protects the drive from corrosion caused by the propellers.
- Shock-absorbing rubber bushing reduces vibrations and stress on the drivetrain.
- Three-blade front propeller and three-blade rear propeller.
- Type F has straight splines, type FH has helical (spiral) splines.

### Type F for DPS, DPS-A (straight splines)

DIM	Set	Front	Rear	DIM	Set	Front	Rear
F 2	3857563	3857557	3857558	F 6	3851496	3851466	3851476
F 3	3857564	3857559	3857560	F 7	3851497	3851467	3851477
F 4	3851494	3851464	3851474	F 8	3851498	3851468	3851478
F 5	3851495	3851465	3851475	F 9	3851499	3851469	3851479

### Type FH for DPS-B (helical/spiral splines)

DIM	Set	Front	Rear	DIM	Set	Front	Rear
FH 2	3885838	3885846	3885847	FH 6	3885842	3885854	3885855
FH 3	3885839	3885848	3885849	FH 7	3885843	3885857	3885859
FH 4	3885840	3885850	3885851	FH 8	3885844	3885860	3885861
FH 5	3885841	3885852	3885853	FH 9	3885845	3885862	3885863

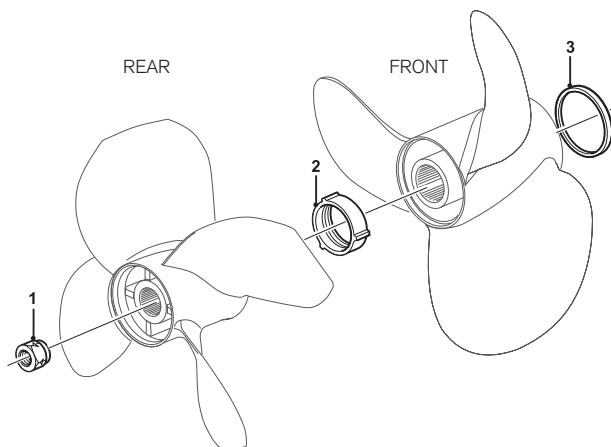

### Installation hardware, type D, I, IH, F, FH

Pos	Part No	Item
1	21631162	Propeller nut, rear *)
2	3851569	Propeller nut, front
3	3851600	Ring (for F7, F8, F9, FH7, FH8, FH9)

Pos	Part No	Item
	3862797	Tool, front
	3862808	Tool, rear
	3855516	Tool, front and rear propeller nut

\*) Included in Type I propeller sets.

# DPH Drives

## Type G – Nibral Duoprop propellers

Designed to capture the tremendous torque from the D4 and D6 engines, the patented blade geometry provides optimal interaction between front and rear propellers for outstanding efficiency and smooth and comfortable operation. The large blade area and great strength ensure maximum grip and maneuverability. The extremely strong nibral (nickel-bronze-aluminum) alloy ensures minimum growth and excellent durability. Complete with shock-absorbing rubber bushing and galvanic isolation makes it perfectly matched for the DPH-drive.



- Patented blade geometry, outstanding efficiency and comfort.
- Excellent durability, minimal marine growth.
- Extremely strong nibral (nickel-bronze-aluminum) alloy.
- Galvanic isolation protects the drive from corrosion caused by the propellers.
- Shock-absorbing rubber bushing reduces vibrations and stress on the drivetrain.
- Three-blade front propeller and four-blade rear propeller.

DIM	Set	Front	Rear	DIM	Set	Front	Rear
G2	22898642	22898622	22898632	G7	22898647	22898627	22898637
G3	22898643	22898623	22898633	G8	22898648	22898628	22898638
G4	22898644	22898624	22898634	G9	22898649	22898629	22898639
G5	22898645	22898625	22898635	G10	22898650	22898630	22898640
G6	22898646	22898626	22898636				

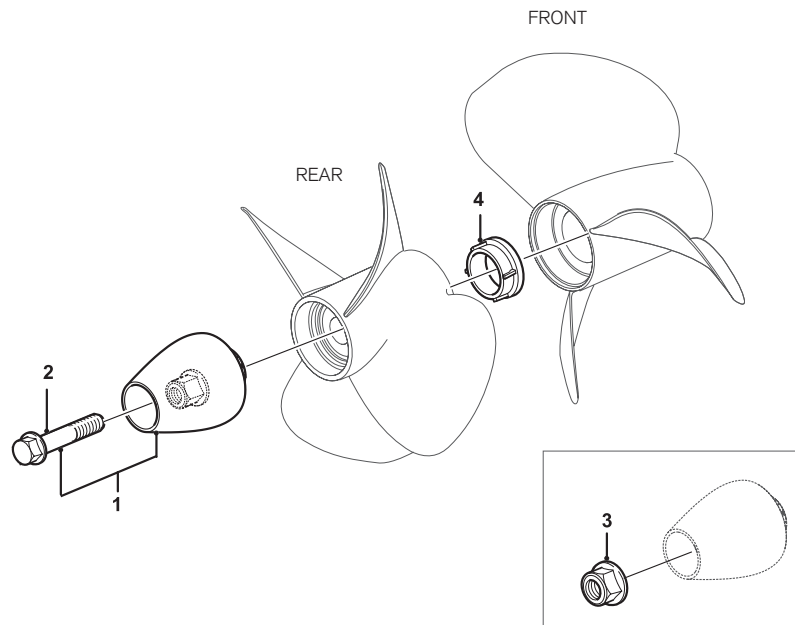

## Installation hardware, type G

The propeller cone (1) has an integrated rear propeller nut and replaces previous propeller cone with separate rear propeller nut.

Pos	Part No	Item
1	21829326	Propeller cone kit*
2	991609	Lock bolt M12**
3	3863213	Propeller nut, rear***

Pos	Part No	Item
4	3863211	Propeller nut, front
	21318669	Tool

\* Propeller cone kit including propeller cone with integrated rear propeller nut and lock bolt (2).  
 \*\* For newer drives with internal threaded propeller shaft intended for lock bolt (from SN 302029042).  
 \*\*\* For previous version of propeller cone with separate rear propeller nut.

# FWD Drives

## Type K – Stainless-steel Duoprop propellers

Specifically designed for the Volvo Penta Forward Drive. These propellers are made of a strong and durable stainless-steel to provide excellent acceleration and top speed. The patented bushing made of a naval brass reduces vibrations, stress on the drivetrain components and prevents corrosion by galvanically isolating the stainless-steel propeller from the aluminum drive casting.



- Specifically designed for the Volvo Penta Forward Drive.
- Strong and durable stainless-steel for excellent acceleration and top speed.
- Patented bushing reduces vibrations and stress on the drivetrain.
- Galvanic isolation protects the drive from corrosion caused by the propellers.
- Patented flow deflector minimizes pressure and wear on the propeller shaft seals.
- Three-blade front propeller and three-blade rear propeller.

DIM	Set	Front	Rear	DIM	Set	Front	Rear
K2	22417005	22414377	22414383	K5	22417008	22414380	22414386
K3	22417006	22414378	22414384	K6	22417009	22414381	22414387
K4	22417007	22414379	22414385	K7	22417010	22414382	22414388

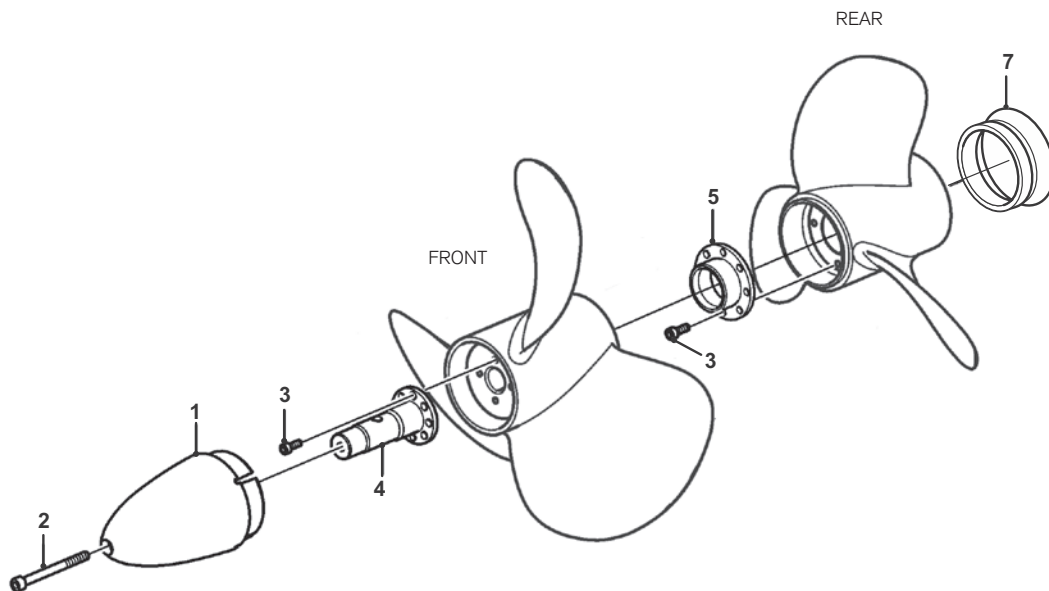

### Installation hardware, type K

Pos	Part No	Item
1	22592621	Propeller hardware kit*
2	22413546	Propeller cone
3	60111646	Hex socket screw
4	963683	Hex socket screw

Pos	Part No	Item
5	22477740	Propeller nut, front
6	22477738	Propeller nut, rear
7	22436582	Flow deflector

\* Propeller hardware kit including item 2, 3, 4, 5, 6.

# DPR Drives

## Type GR – Stainless-steel Duoprop propellers

Developed for the DPR high-speed drive to maximize performance and efficiency. The high-performance blade geometry and great strength ensure maximum grip and maneuverability. Made of high-strength stainless-steel alloy for excellent durability and corrosion resistance. Shock-absorbing rubber bushing and galvanic isolation makes it perfectly matched for the DPR high-speed drive.

- High-performance blade geometry, great strength, thin blades.
- Excellent durability and corrosion resistance.
- Shock-absorbing rubber bushing reduces vibrations and stress on the drivetrain.
- Galvanic isolation protects the drive from corrosion caused by the propellers.
- Three-blade front propeller and three-blade rear propeller.



DIM	Set	Front	Rear
GR7	3863492	3863501	3863502
GR8	3863493	3863503	3863504
GR9	3863494	3863505	3863506

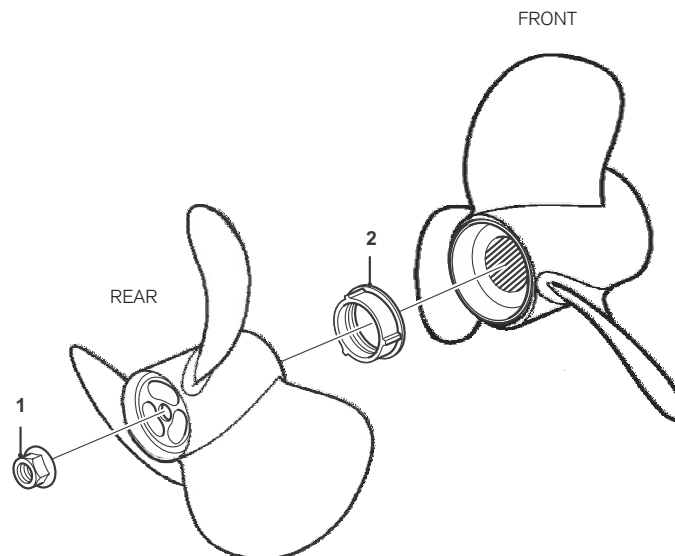

## Installation hardware, type GR

Pos	Part No	Item	Pos	Part No	Item
1	3863213	Propeller nut, rear		21318669	Tool
2	3863211	Propeller nut, front			





# DPX Drives

## Type E – Stainless-steel Duoprop propellers

Developed for the DPX high-speed drive to provide maximum performance and efficiency in speeds up to 75 knots. The high-performance blade geometry and great strength ensure maximum grip and maneuverability. Made of high-strength stainless-steel for excellent durability and corrosion resistance. Shock-absorbing rubber bushing and galvanic isolation makes it perfectly matched for the DPX high-speed drive.



- High-performance blade geometry, great strength, thin blades.
- Excellent durability and corrosion resistance.
- Designed for speeds up to 75 knots.
- Galvanic isolation protects the drive from corrosion caused by the propellers.
- Shock-absorbing rubber bushing reduces vibrations and stress on the drivetrain.
- Three-blade front propeller and three-blade rear propeller.

DIM	Set 	Front 	Rear 
E 2	3860065	872422	3860011
E 3	3860066	872423	3860012
E 4	3860067	872424	3860013

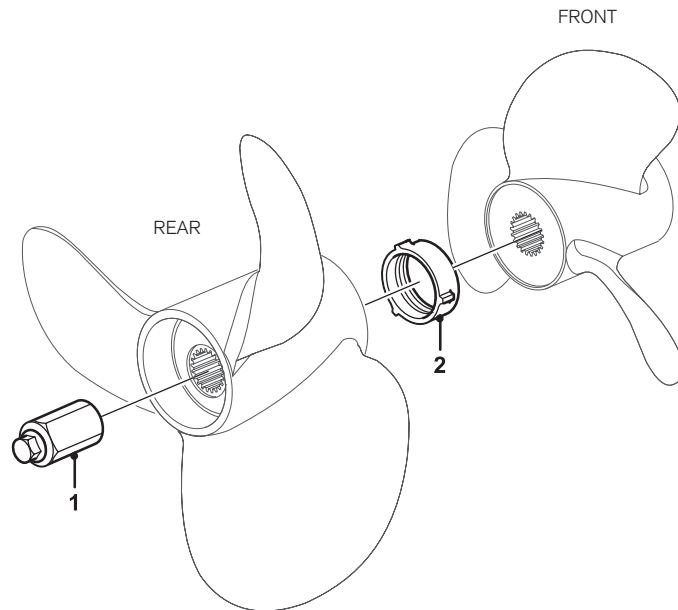

### Installation hardware, type E

Pos	Part No	Item
1	872179	Propeller nut, rear
2	3851335	Propeller nut, front

Pos	Part No	Item
	885195	Tool

# 280, 290, DP Drives

## Type J – Aluminum Duoprop propellers

A completely modern aluminum propeller designed for our classic Duoprop drives. The patented blade geometry and large propeller diameter provides optimal efficiency as well as quiet and smooth operation. A special high-strength aluminum alloy and squeeze casting process makes the propellers stronger and more durable than traditional die-cast propellers. Four layers of paint ensures excellent corrosion protection performance.



- Patented blade geometry and large active propeller diameter.
- Strong and durable high-strength aluminum alloy.
- Excellent anti-corrosion performance.
- Three-blade front propeller and four-blade rear propeller.
- Replaces type A and type B propellers (see below for details).

**Note!** Always use type C stainless steel propellers in engines exceeding 240 hp or capable of speeds above 38 knots (45 mph). See next page.

DIM	Set	Front	Rear	DIM	Set	Front	Rear
J 2	21924262	21924222	21924242	J 6	21924266	21924226	21924246
J 3	21924263	21924223	21924243	J 7	21924267	21924227	21924247
J 4	21924264	21924224	21924244	J 8	21924268	21924228	21924248
J 5	21924265	21924225	21924245	J 9	21924269	21924229	21924249
				J 10	21924270	21924230	21924250

Installation hardware, see next page.

## Upgrade from type A or type B propellers to type J propellers

To ensure the best performance for your boat, consult your Volvo Penta dealer for advice on the right propeller size for your drive and engine.

**Note!** Do not mix Type A, B and J propellers. Always use propellers of the same type and size on the drive (or on both drives in twin installations).

## Type A – Aluminum Duoprop propellers

Type A propeller sets are replaced by type J propeller sets. However, Type A propellers (front and rear) are sold individually as spare parts. However, complete sets of A0 and A1 are available.

DIM	Set	Front	Rear	DIM	Front	Rear
A 0	872270	872259	872264	A 6	854779	854789
A 1	854764	854774	854784	A 7	854780	854790
A 2		854775	854785	A 8	854781	854791
A 3		854776	854786	A 9	854782	854792
A 4		854777	854787	A 10	854783	854793
A 5		854778	854788			

Installation hardware, see next page.

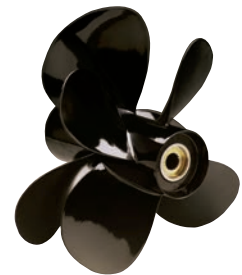

## Type B – Aluminum Duoprop propellers

Type B propeller sets are replaced by type J propeller sets. However, Type B propellers (front and rear) are sold individually as spare parts.

DIM	Front	Rear	DIM	Front	Rear
B 1	854822	854830	B 5	854826	854834
B 2	854823	854831	B 6	854827	854835
B 3	854824	854832	B 7	854828	854836
B 4	854825	854833	B 8	854829	854837

Installation hardware, see next page.









# 280, 290, DP Drives

## Type C – Stainless-steel Duoprop propellers

This is the perfect upgrade for enhanced performance, strength and durability. It provides better acceleration and higher top speed through greater strength and thinner blades versus a comparable aluminum propeller. The stainless-steel material makes the propellers durable and highly resistant to cavitation, damage and corrosion. Complete with shock-absorbing rubber bushing and galvanic isolation in the hub.



- Enhanced acceleration and top speed versus a comparable aluminum propeller.
- Excellent strength, durability and corrosion resistance.
- Shock-absorbing rubber bushing reduces vibrations and stress on the drivetrain.
- Galvanic isolation protects the drive from corrosion caused by the propellers.
- Three-blade front propeller and three-blade rear propeller.

DIM	  			DIM	  		
	Set	Front	Rear		Set	Front	Rear
C 2	3588222	3587864	3587870	C 5	3588225	3587867	3587873
C 3	3588223	3587865	3587871	C 6	3588226	3587868	3587874
C 4	3588224	3587866	3587872	C 7	3588227	3587869	3587875

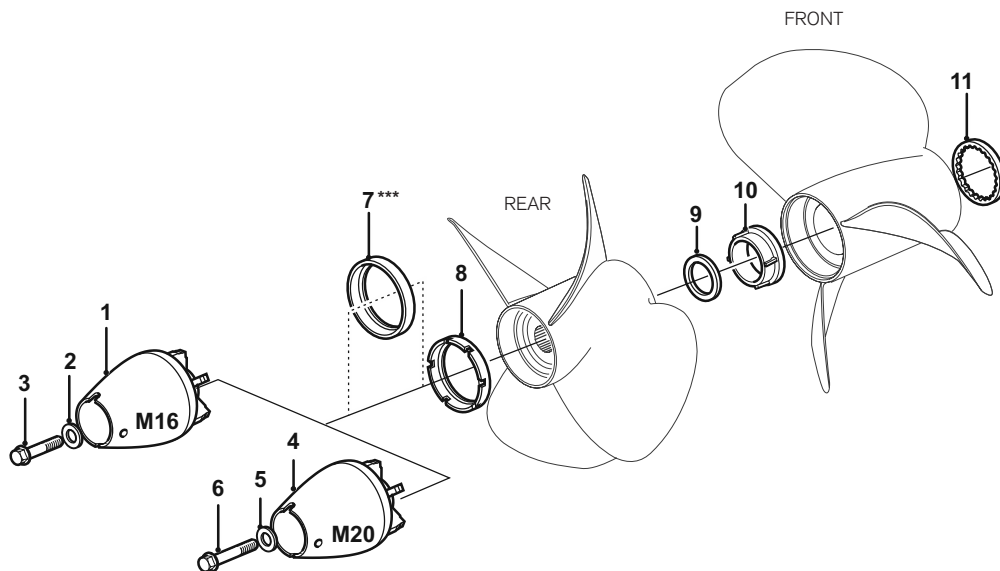

### Installation hardware, type A, B, C, J

Pos	Part No	Item
1	872614	Propeller cone kit M16*
2	941670	Washer M8
3	852216	Lock screw M8
4	872549	Propeller cone kit M20**
5	943194	Washer M12
6	872546	Lock screw M12
7	853676	Spacer ring for propeller cone ***

Pos	Part No	Item
8	854294	Plastic washer
9	3858458	Thrust ring
10	3851334	Propeller nut
11	3858457	Thrust ring
	854668	Tool, propeller cone M16
	873058	Tool kit, propeller nut

\* Propeller cone kit M16 including item 1, 2, 3, 7, 8.  
 \*\* Propeller cone kit M20 including item 4, 5, 6, 7, 8.  
 \*\*\* Spacer ring for propeller cone only to be used with type A propellers.





## Propellers for Volvo Penta IPS

# Faster, further, cleaner and quieter

When Volvo Penta launched the revolutionary IPS (Inboard Performance System) we set a completely new standard in efficiency, comfort and maneuverability. By turning the propellers around to a forward-facing position, the world of boating changed forever. These twin counter-rotating propellers form an important part of the hydro-dynamically designed propulsion unit – pulling the boat through the water rather than pushing it.

The state-of-the-art IPS propellers are developed, tested and manufactured with the highest precision. Not only do they contribute to outstanding performance

and fuel efficiency, but also handling and onboard comfort – all this while securing the service life of your drive.

**Precise balancing** gives minimal vibrations, quiet and comfortable operation. It is also essential for efficiency and minimizes wear on the drivetrain.

**Fully CNC machining** ensures exact tolerances and perfect geometry of each propeller, which results in total precision and outstanding performance.

**Optimal interaction** between the front and rear propeller ensures maximum performance and fuel efficiency throughout the entire speed range, as well as smooth and comfortable running.

**Patented Flow deflector** at the rear propeller controls the water flow and minimizes pressure and wear on the propeller shaft seals.

**Extremely strong** and specially developed nibral (nickel-bronze-aluminum) alloy ensures minimum growth, excellent durability and corrosion resistance.

**Optimized torque distribution** between front and rear propellers ensures that the drive works with the load it is designed for – essential in preserving the life of the drivetrain.

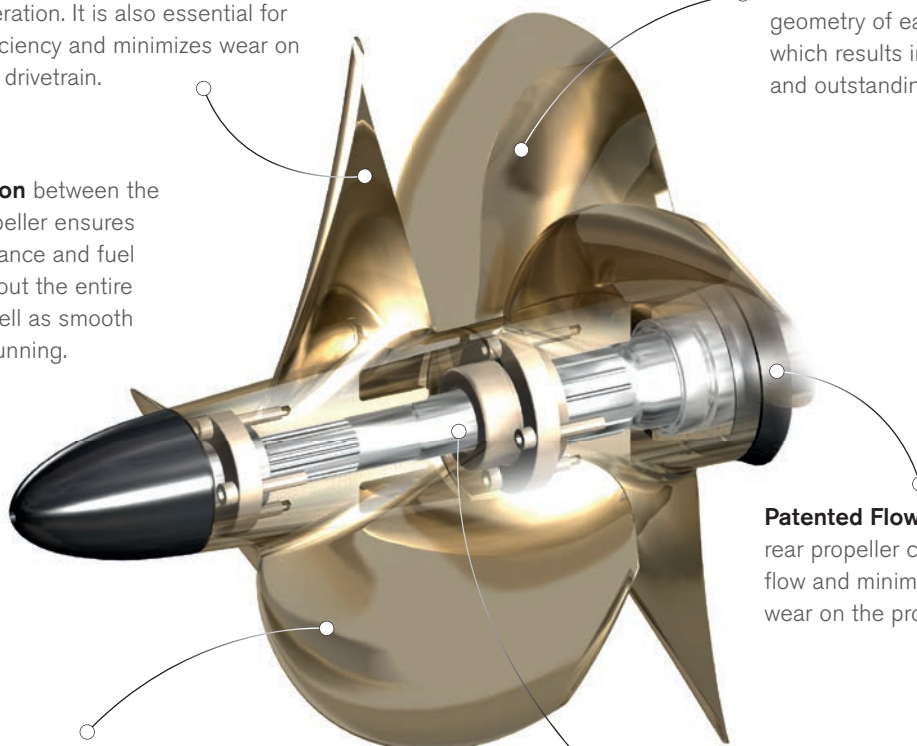



# IPS 1

## Type T/TS – Nibral propellers

Specifically developed for IPS with D4 and D6 engines to give outstanding efficiency, onboard comfort and maneuverability.

- Extremely strong and specially developed nibral (nickel-bronze-aluminum) alloy.
- Minimum growth, excellent durability and corrosion resistance.
- Patented flow deflector minimizes pressure and wear on propeller shaft seals.
- Three-blade front propeller and four-blade rear propeller.



DIM	Set	Front	Rear	DIM	Set	Front	Rear
TS3	21368025	21368026	21368027	T5	3861101	3861102	3861103
TS4	21368016	21368017	21368018	T6	3861104	3861105	3861106
TS5	21258473	21258474	21258475	T7	3861107	3861108	3861109
TS6	21368012	21368013	21368014	T8	3861110	3861111	3861112
T2	3861092	3861093	3861094	T9	3861113	3861114	3861115
T3	3861095	3861096	3861097	T10	3861116	3861117	3861118
T4	3861098	3861099	3861100				

The type T/TS series covers applications from semi-planing boats with moderate top speeds to planing boats with high top speeds.

TS3	TS4	TS5	TS6	T2	T3	T4	T5	T6	T7	T8	T9	T10
Moderate top speed						High top speed						

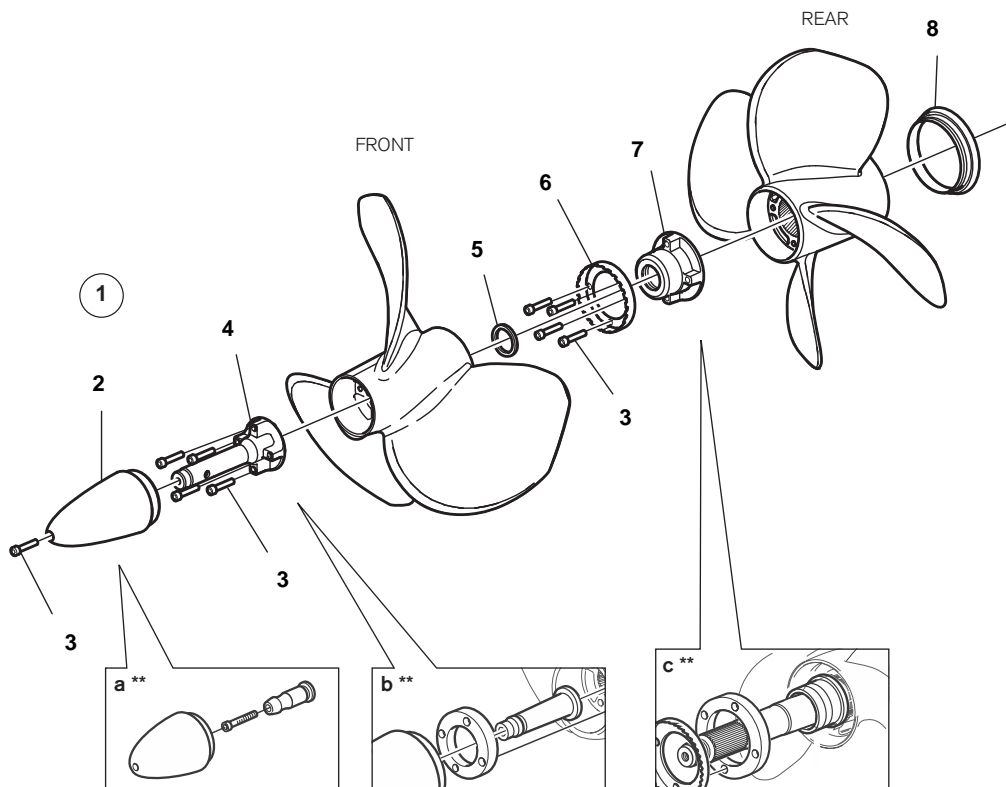

## Installation hardware, type T/TS

Pos	Part No	Item
1	22659020	Propeller cone kit*
2	22072153	Propeller cone
3	963699	Hex socket screw
4	22001844	Propeller nut, front
5	22005360	Felt washer

Pos	Part No	Item
6	21686492	Line cutter
7	22001842	Propeller nut, rear
8	3862454	Flow deflector
	85145750	Locking fluid (10 ml)

\* Propeller cone kit consist of Propeller cone (2), 9 pcs Hex socket screw (3), Propeller nut, front (4), grease and a tool.

\*\* IPS1-A, IPS1-B, IPS1-C earlier propeller cone and hardware (a) is replaced by propeller cone kit (1). (b) Lock plate and propeller nut front is replaced by a new propeller nut front (4). (c) Lock ring and lock nut rear is replaced by Felt washer (5) and Propeller nut, rear (7).

# IPS 15

**NEW**

## Type N/NS – Nibral propellers

Specifically developed for IPS with D8 engines to give outstanding efficiency, onboard comfort and maneuverability.

- Extremely strong and specially developed nibral (nickel-bronze-aluminum) alloy.
- Minimum growth, excellent durability and corrosion resistance.
- Patented flow deflector minimizes pressure and wear on propeller shaft seals.
- Three-blade front propeller and four-blade rear propeller.



DIM	Set	Front	Rear	DIM	Set	Front	Rear
NS4	21916044	21915974	21915994	N4	21808224	21808194	21808214
NS5	21916045	21915975	21915995	N5	21808225	21808195	21808215
N1	21808221	21808191	21808211	N6	21808226	21808196	21808216
N2	21808222	21808192	21808212	N7	21808227	21808197	21808217
N3	21808223	21808193	21808213				

The type N/NS series covers applications from semi-planing boats with moderate top speeds to planing boats with high top speeds.

NS4	NS5	N1	N2	N3	N4	N5	N6	N7
Moderate top speed				High top speed				

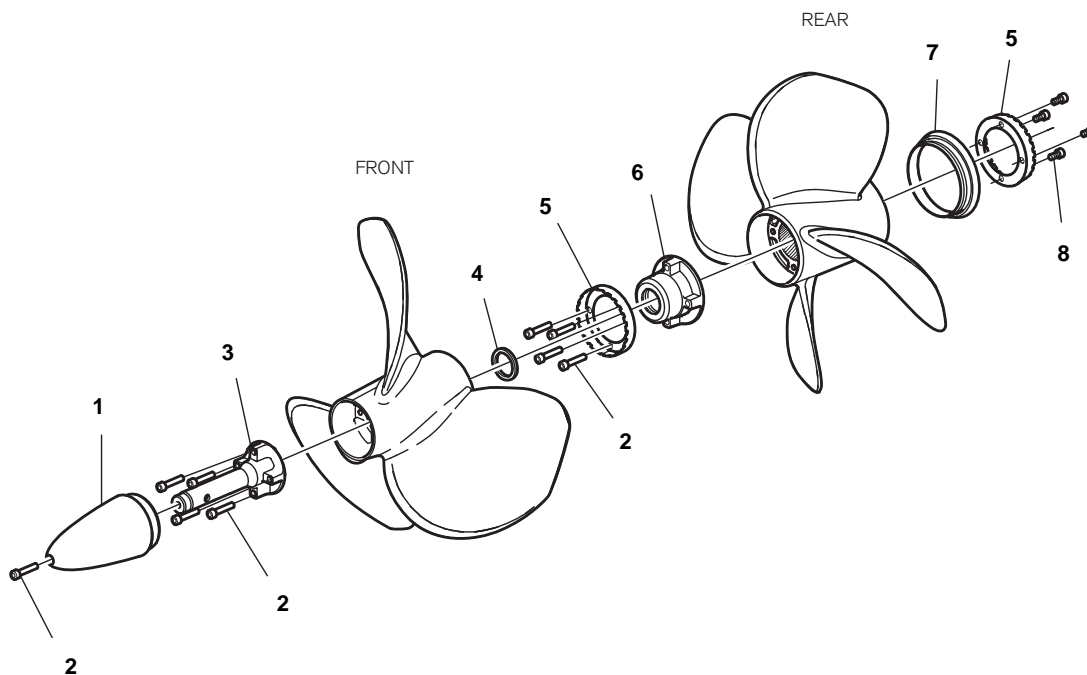

## Installation hardware, type N/NS

Pos	Part No	Item
1	21815881	Propeller cone
2	963699	Hex socket screw
3	21815875	Propeller nut, front
4	21816205	Felt washer

Pos	Part No	Item
5	21913550	Line cutter
6	21815872	Propeller nut, rear
7	21808200	Flow deflector
8	963696	Hex socket screw
	85145750	Locking fluid (10 ml)

# IPS 2

## Type P/PS – Nibral propellers

Specifically developed for IPS with D11 engines to give outstanding efficiency, onboard comfort and maneuverability.

- Extremely strong and specially developed nibral (nickel-bronze-aluminum) alloy.
- Minimum growth, excellent durability and corrosion resistance.
- Patented flow deflector minimizes pressure and wear on propeller shaft seals.
- Three-blade front propeller and four-blade rear propeller.



DIM	Set	Front	Rear	DIM	Set	Front	Rear
PS4	21622828	21622814	21622823	P4	3843962	3843963	3843964
PS5	21622827	21622813	21622822	P5	3843965	3843966	3843967
P1	3843980	3843981	3843982	P6	3843968	3843969	3843970
P2	3843956	3843957	3843958	P7	3843971	3843972	3843973
P3	3843959	3843960	3843961				

The type P/PS series covers applications from semi-planing boats with moderate top speeds to planing boats with high top speeds.

PS4	PS5	P1	P2	P3	P4	P5	P6	P7
Moderate top speed					High top speed			

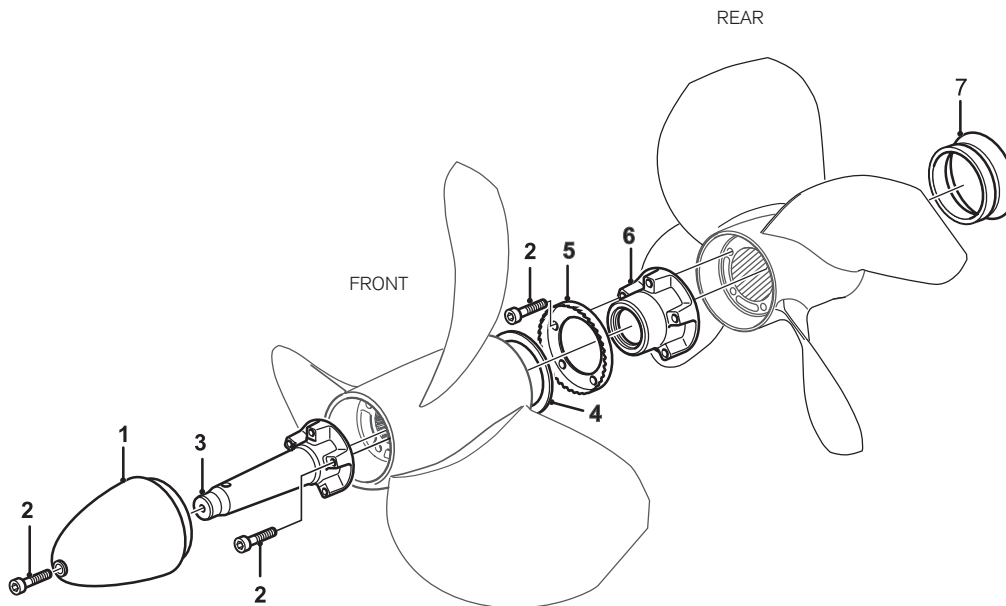

## Installation hardware, type P/PS

Pos	Part No	Item
1	21154200	Propeller cone
2	963699	Hex socket screw
3	21154206	Propeller nut, front
4	3593639	Felt washer

Pos	Part No	Item
5	21686494	Line cutter
6	21154277	Propeller nut, rear
7	3843992	Flow deflector
	85145750	Locking fluid (10 ml)

# IPS 3

## Type Q/QS – Nibral propellers

Specifically developed for IPS with D13 engines to give outstanding efficiency, onboard comfort and maneuverability.

- Extremely strong and specially developed nibral (nickel-bronze-aluminum) alloy.
- Minimum growth, excellent durability and corrosion resistance.
- Patented flow deflector minimizes pressure and wear on propeller shaft seals.
- Three-blade front propeller and four-blade rear propeller.



DIM	Set	Front	Rear	DIM	Set	Front	Rear
QS5	21821365	21821255	21821265	Q4	21433624	21433604	21433614
Q1	21433621	21433601	21433611	Q5	21433625	21433605	21433615
Q2	21433622	21433602	21433612	Q6	21433626	21433606	21433616
Q3	21433623	21433603	21433613	Q7	21433627	21433607	21433617

The type Q/QS series covers applications from semi-planing boats with moderate top speeds to planing boats with high top speeds.

QS5	Q1	Q2	Q3	Q4	Q5	Q6	Q7
Moderate top speed				High top speed			

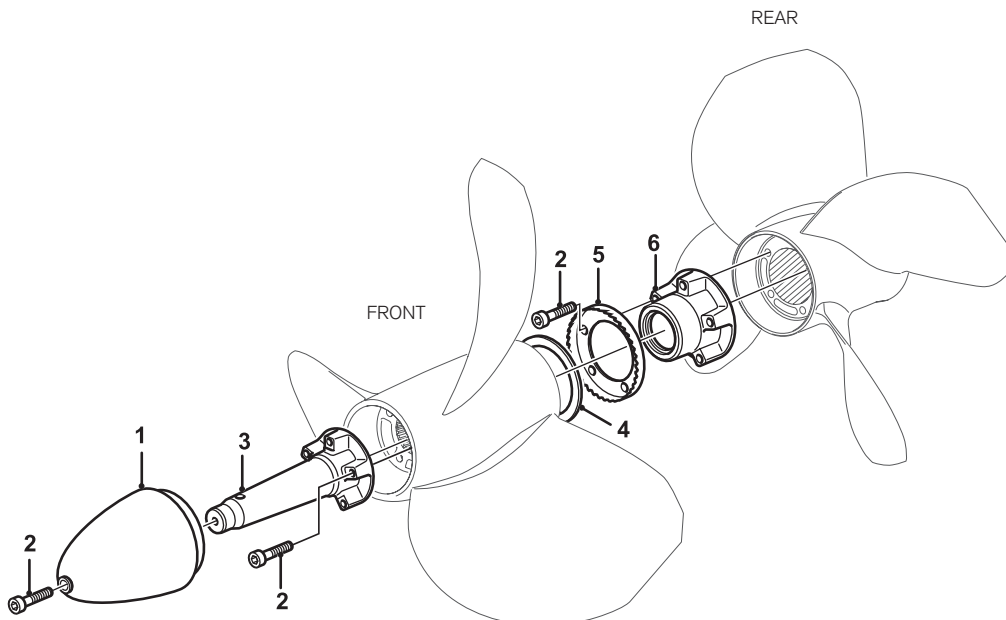

### Installation hardware, type Q/QS

Pos	Part No	Item
1	40005165	Propeller cone
2	963699	Hex socket screw
3	40005157	Propeller nut, front
4	21235219	Felt washer

Pos	Part No	Item
5	21686496	Line cutter
6	40005161	Propeller nut, rear
	85145750	Locking fluid (10 ml)

# IPS 3

**NEW**

## Type QE – Nibral propellers

The QE propeller is a variant of the standard high performance Q propeller, featuring thicker blades and a slightly larger blade area. This adds strength and overall robustness, but will reduce efficiency and top speed. QE propellers could be a good choice for marine commercial vessels when operating in an area of temporary debris and flotsam, such as crushed ice and other floating objects that can damage the propeller.



When considering changing to the QE propeller, please consult your local dealer or local Volvo Penta Sales Application Engineer for size guidance and speed calculations.

**Note!** The type QE propeller is approved for D13 IPS900 & IPS1050.

DIM	Set	Front	Rear	DIM	Set	Front	Rear
QE1	22059721	22059611	22059631	QE3	22059723	22059613	22059633
QE2	22059722	22059612	22059632	QE4	22059724	22059614	22059634

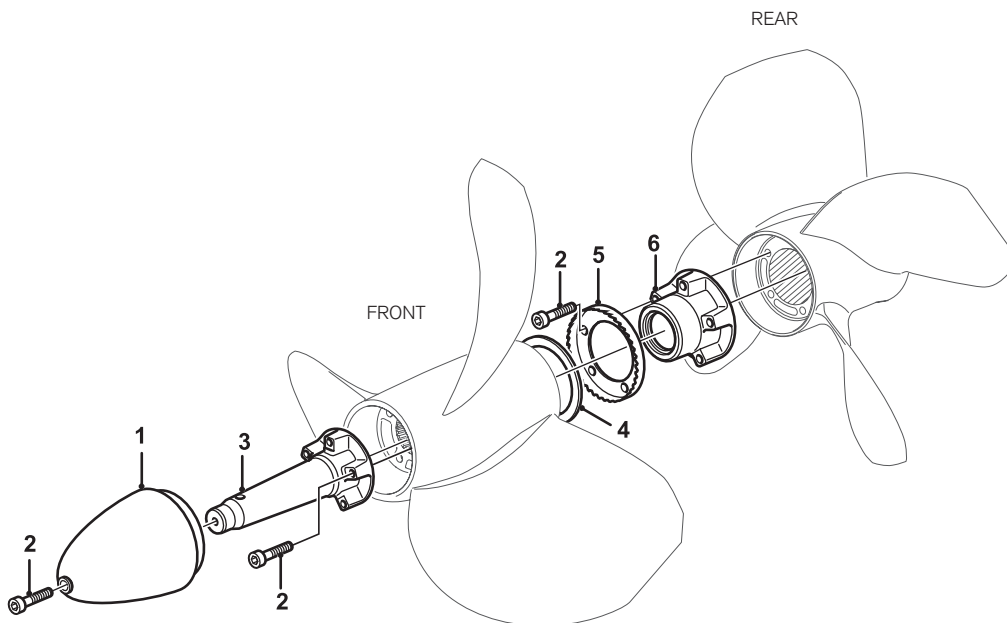

### Installation hardware, type QE

Pos	Part No	Item
1	40005165	Propeller cone
2	963699	Hex socket screw
3	40005157	Propeller nut, front
4	21235219	Felt washer

Pos	Part No	Item
5	21686496	Line cutter
6	40005161	Propeller nut, rear
	85145750	Locking fluid (10 ml)



# GREASE IT UP



## Grease for propeller components

Volvo Penta water-resistant grease is designed to provide excellent adhesion, water resistance and load-carrying properties, as well as long-term protection against corrosion. It is a multi-purpose premium grease and is highly recommended for greasing propeller shafts, folding propellers and all other propeller components.

Learn more on page 41





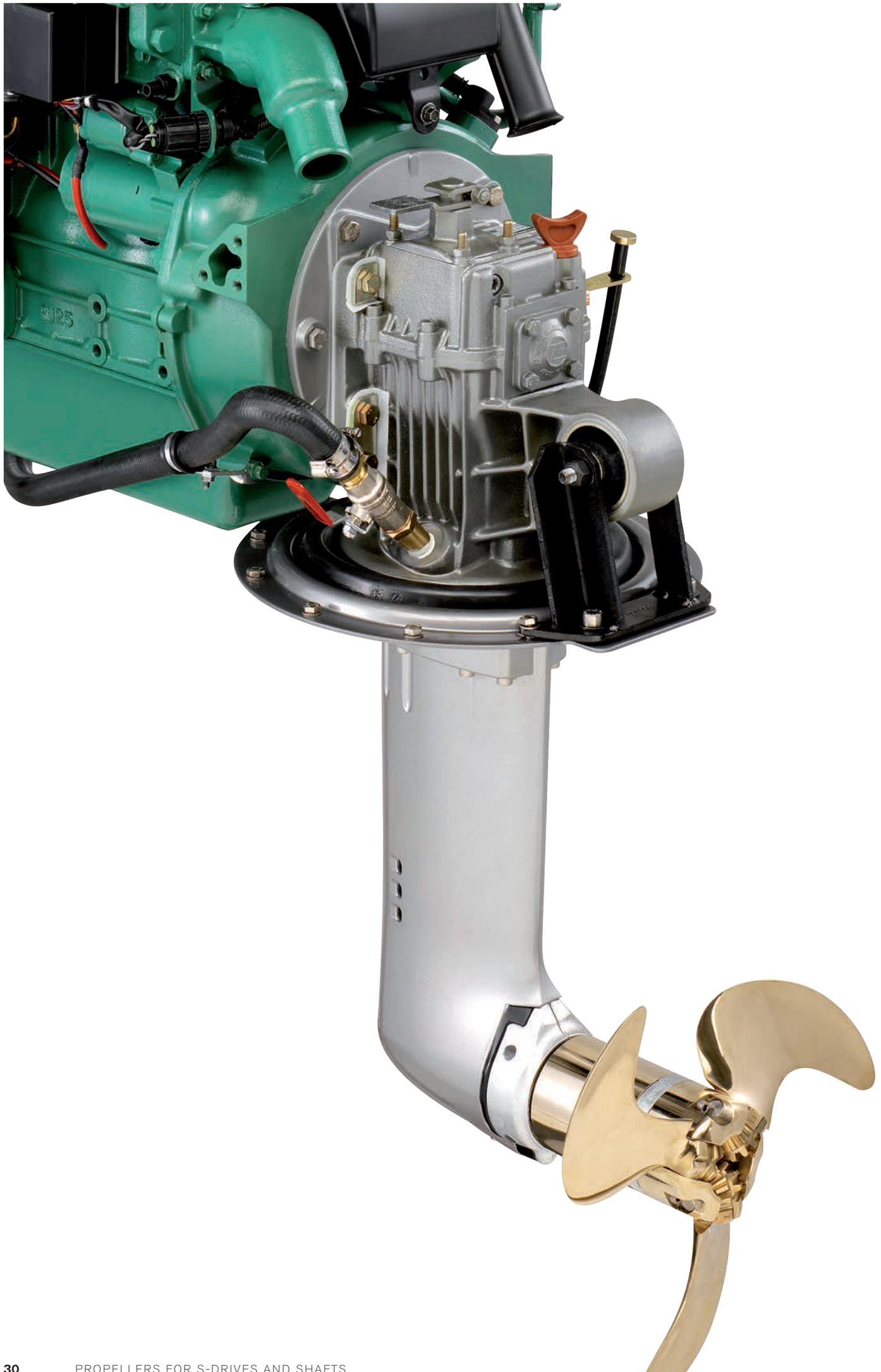

## Folding propellers for S-drive and shaft

# Sailing without compromise

Volvo Penta folding propellers offer the best of both worlds – minimal drag while sailing combined with the high thrust of a fixed propeller while motoring – even in reverse.

The unique and patented design always ensures quick and safe opening of the blades for excellent close-quarter maneuverability and minimal stopping distance. Whether you choose a 2, 3 or 4-blade model, the swept blade design (high-skew) provides extremely smooth running - virtually eliminating noise

and vibrations for excellent comfort during motoring. And what's more, the reduced drag under sail increases speed by up to 1.5 knots compared with a fixed propeller. Put all this together and you greatly increase your sailing pleasure.

**Powerful thrust, even in reverse** thanks to the highly-efficient and patented blade geometry. This means excellent close-quarter maneuverability and short stopping distance.

**Excellent durability** and corrosion resistance thanks to specially developed nibral (nickel-bronze-aluminum) alloy.

**High-skew blade design** reduces pressure pulses to ensure smooth, low-noise operation with minimal vibrations.

**The reliable and consistent** conical teeth mechanism ensures synchronized opening and closing of the blades.

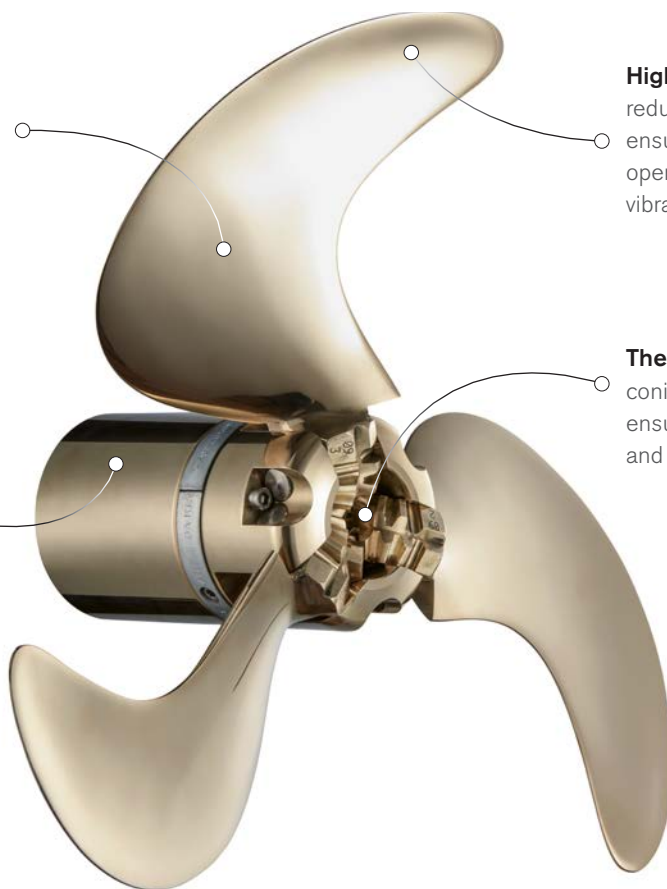

# Folding propellers for S-drive and shaft

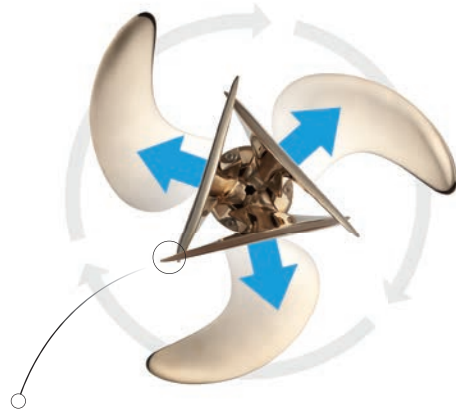

## Minimizing drag and increasing speed

Volvo Penta folding propellers improve the performance of your boat minimizing drag and increasing speed – up to 1.5 knots under sail, compared with a fixed propeller. In addition, the sleek profile also reduces the risk of snagging ropes, nets and debris when sailing.

## Instant and powerful response - even in reverse.

The patented design, with protruding blade tips ensures an instant opening action when the reverse gear is engaged. As soon as the propeller begins to rotate, mounting water pressure on the blade tips forces the blades to open. Centrifugal force then finalizes the opening action.

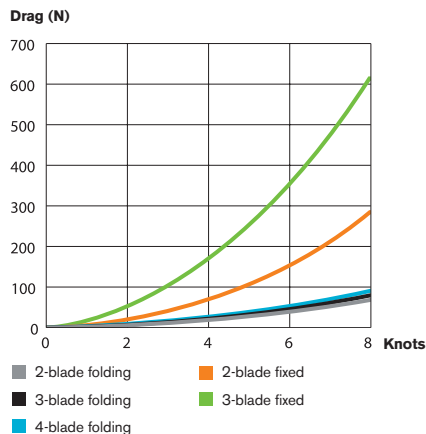

*The test was carried out by SSPA Maritime Consulting. All propellers were mounted on a Saildrive propulsion system.*



The graph shows the difference in propeller drag and how rapidly the drag increases with fixed propellers and higher speed. At 8 knots for example, a 3-blade fixed propeller produces more than six times the drag of a 3-blade folding propeller. This means a typical journey across the English Channel can be reduced by up to 4 hours thanks to lower drag.

## Rubber bushing and galvanic isolation.

Hubs for saildrive propellers include a shock-absorbing rubber bushing to minimize stress on the drivetrain caused by gear changes. In addition, the bushing is designed to galvanically isolate the propeller from the saildrive - preventing galvanic corrosion caused by the propeller.

# S-drive and shaft

## 2-blade folding propeller for 5–40 hp



Designed for engines from 5 up to 40 hp. Available in multiple sizes and pitches for both S-drives and shafts. Made of extremely strong and durable nibral (nickel-bronze-aluminum) alloy.

- Powerful thrust even in reverse thanks to patented blade geometry
- Smooth, low-noise operation with minimal vibrations
- Safe opening with quick response in both forward and reverse
- Rubber bushing and galvanic isolation (hubs for S-drives)

**Note!** For a complete propeller, order one blade kit and one hub kit. Propeller size has to be calculated to match engine and gear ratio, please contact your Volvo Penta dealer.

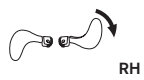

### Blade kits

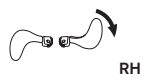
S-Drive & Shaft		Shaft		S-Drive & Shaft		Shaft	
Ø x PITCH	 LH	 RH	Ø x PITCH	 LH	 RH		
14 x 7	21629132	21629136	16 x 11	21629182	21629186		
14 x 8	21629140	21629144	17 x 11	21629190	21629194		
15 x 8	21629147	21629152	17 x 12	21629198	21629201		
15 x 10	21629158	21629167	18 x 12	21629205	21629211		
16 x 10	21629173	21629177	19 x 13	21629214	21629218		

**Blade kit includes:** Blades, hex key for locking screw (pos 11), locking fluid and installation instruction.

### Hub kits

Hub kit for S-drives		Hub kit for shafts	
110S, 120S, MS25S, 130S, 150S	21630720	Pre-drilled hub*	21630725
<b>Hub kit for metric standard shaft (1:10 taper)</b>		<b>Hub kit for SAE standard shaft (1:16 taper)</b>	
25 mm shaft (key 6 mm)	21630721	1" shaft (key 5/16")	21630723
30 mm shaft (Key 8 mm)	21630722	1 1/4" shaft (key 5/16")	21630724

**Hub kit includes:** Zinc anodes, locking fluid and installation hardware listed in the table below. \* Hub pre-drilled with 8 mm hole. Require final machining to the required shaft diameter and taper. Suitable for shafts up to 31,75 mm (1 1/4").

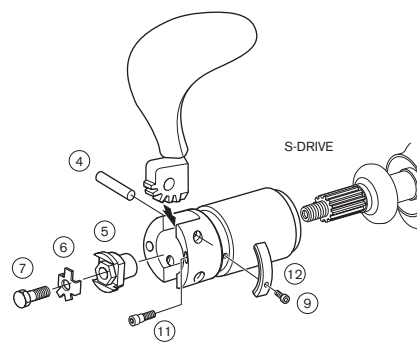
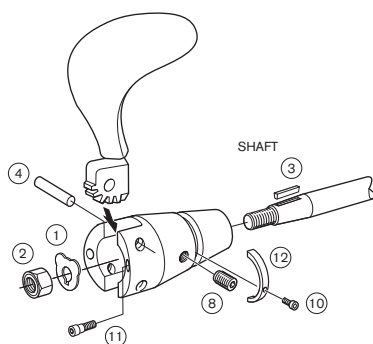

### Installation hardware, 2-blade folding propeller

Pos	Part No	Qty	Item
1	873475	1	Tab washer, M16
1	873488	1	Tab washer, M20
2	873473	1	Nut, prop shaft, M16
2	873486	1	Nut, prop shaft, M20
3	873474	1	Key, prop shaft, Ø25mm
3	873487	1	Key, prop shaft, Ø30mm
4	21626924	2	Shaft <sup>1,2)</sup>
5	3584466	1	Propeller nut <sup>1)</sup>

Pos	Part No	Qty	Item
6	3851994	1	Lock washer <sup>1)</sup>
7	946730	1	Hexagon screw <sup>1)</sup>
8	3581246	2	Screw <sup>2)</sup>
9	963677	2	Hex. socket screw <sup>1)</sup>
10	963675	2	Hex. socket screw <sup>2)</sup>
11	3595221	2	Lock screw <sup>1,2)</sup>
12		2	Zinc anode <sup>1,2,3)</sup>
	1161053	1	Locking fluid (10 ml) <sup>1,2)</sup>

1) Included in hub kit for S-drive. 2) Included in hub kit for shaft. 3) For part number, see chapter "Related items".



# S-drive and shaft

## 3-blade folding propeller for 20–60 hp



Designed for engines from 20 up to 60 hp. Available in multiple sizes and pitches for both S-drives and shafts. Made of extremely strong and durable nibral (nickel-bronze-aluminum) alloy.

- Powerful thrust even in reverse thanks to patented blade geometry
- Smooth, low-noise operation with minimal vibrations
- Safe opening with quick response in both forward and reverse
- Rubber bushing and galvanic isolation (hubs for S-drives)

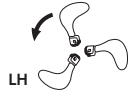
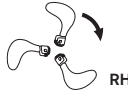
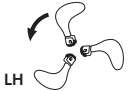

**Note!** For a complete propeller, order one blade kit and one hub kit. Propeller size has to be calculated to match engine and gear ratio, please contact your Volvo Penta dealer.

## Blade kits

S-Drive & Shaft		Shaft		S-Drive & Shaft		Shaft	
Ø x PITCH			Ø x PITCH				
14 x 7	—	3583409	17 x 12	3583388	3583417		
14 x 8	—	3583410	18 x 12	3583389	3583418		
14 x 9	3583382	3583411	18 x 13	3583390	3583419		
15 x 9	3583383	3583412	18 x 14	3583391	3583420		
15 x 10	3583384	3583413	18 x 15	3583392	3583421		
16 x 10	3583385	3583414	18 x 16	3584031	3583422		
16 x 11	3583386	3583415	19 x 16	3583393	3583423		
17 x 11	3583387	3583416					

**Blade kit includes:** Blades, hex key for locking screw (pos 10), locking fluid and installation instruction.

## Hub kits

Hub kit for S-drives		Hub kit for shafts	
110S, 120S, MS25S, 130S, 150S	3858955	Pre-drilled hub*	3583428
Hub kit for metric standard shaft (1:10 taper)		Hub kit for SAE standard shaft (1:16 taper)	
25 mm shaft (key 6 mm)	3583424	1" shaft (key 1/4")	3583426
30 mm shaft (Key 8 mm)	3583425	1 1/4" shaft (key 5/16")	3583427

**Hub kit includes:** Zinc anodes, locking fluid and installation hardware listed in the table below. \* Hub pre-drilled with 8 mm hole. Require final machining to the required shaft diameter and taper. Suitable for shafts up to 31,75 mm (1 1/4").

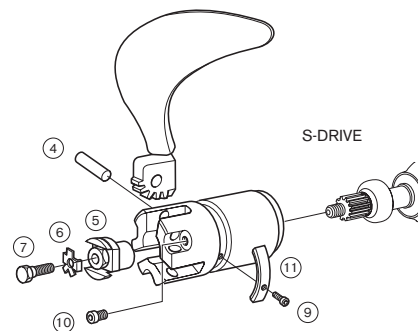
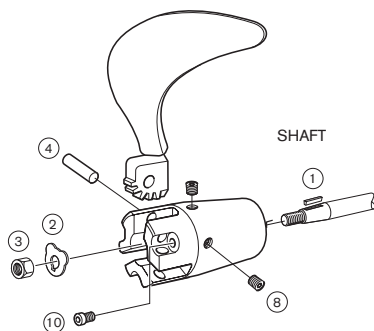

## Installation hardware, 3-blade folding propeller

Pos	Part No	Qty	Item
1	873474	1	Key, prop shaft, Ø25mm
1	873487	1	Key, prop shaft, Ø30mm
2	873475	1	Tab washer, M16
2	873488	1	Tab washer, M20
3	873473	1	Nut, prop shaft, M16
3	873486	1	Nut, prop shaft, M20
4	3581243	3	Shaft <sup>1,2)</sup>
5	3584466	1	Propeller nut <sup>1)</sup>

Pos	Part No	Qty	Item
6	3851994	1	Lock washer <sup>1)</sup>
7	946730	1	Hexagon screw <sup>1)</sup>
8	3581246	2	Screw <sup>2)</sup>
9	963677	3	Hex. socket screw <sup>1,2)</sup>
10	963695	3	Hex. socket screw <sup>1)</sup>
11		2	Zinc anode <sup>1,3)</sup>
	1161053	1	Locking fluid (10 ml) <sup>1,2)</sup>

1) Included in hub kit for S-drive. 2) Included in hub kit for shaft. 3) For part number, see chapter "Related items".

# S-drive and shaft

## 4-blade folding propeller for 55–120 hp

Designed for engines from 55 up to 120 hp. Available in multiple sizes and pitches for both S-drives and shafts. Made of extremely strong and durable nibral (nickel-bronze-aluminum) alloy.

- Powerful thrust even in reverse thanks to patented blade geometry
- Smooth, low-noise operation with minimal vibrations
- Safe opening with quick response in both forward and reverse
- Rubber bushing and galvanic isolation (hubs for S-drives)



**Note!** For a complete propeller, order one blade kit and one hub kit. Propeller size has to be calculated to match engine and gear ratio, please contact your Volvo Penta dealer.

### Blade kits

	S-Drive & Shaft		Shaft		S-Drive & Shaft		Shaft	
Ø x PITCH								
20 x 14	3583917	3583918	22 x 18	3583923	3583924	22 x 20	3583925	3583926
21 x 15	3583919	3583920						
22 x 16	3583921	3583922						

**Blade kit includes:** Blades, hex key for locking screw (pos 10), locking fluid and installation instruction.

### Hub kits

Hub kit for S-drives		Hub kit for metric standard shaft (1:10 taper)	
110S, 120S, MS25S, 130S, 150S	3583927	25 mm shaft (key 6 mm)	3583928
Hub kit for SAE standard shaft (1:16 taper)		Hub kit for metric standard shaft (1:10 taper)	
1 1/4" shaft (key 5/16")	3583931	30 mm shaft (Key 8 mm)	3583929
1 1/2" shaft (key 3/8")	3583932	35 mm shaft (Key 10 mm)	3583930
		40 mm shaft (Key 12 mm)	3584137

**Hub kit includes:** Zinc anodes, locking fluid and installation hardware listed in the table below. \* Hub pre-drilled with 8 mm hole. Require final machining to the required shaft diameter and taper. Suitable for shafts up to 31,75 mm (1 1/4").

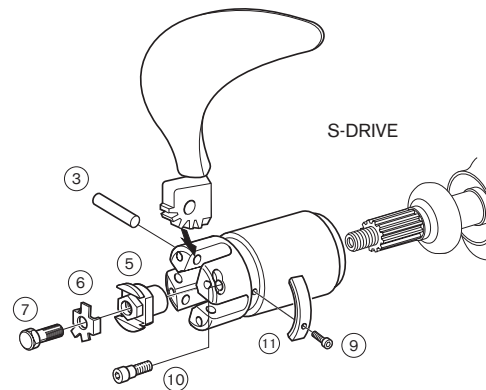
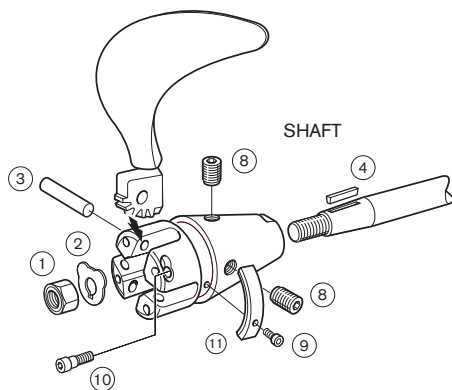

### Installation hardware, 4-blade folding propeller

Pos	Part No	Qty	Item
1	873473	1	Nut, prop shaft, M16
1	873486	1	Nut, prop shaft, M20
1	3587422	1	Nut, prop shaft, M24
2	873475	1	Tab washer, M16
2	873488	1	Tab washer, M20
2	873506	1	Tab washer, M24
3	3583951	4	Shaft <sup>1,2)</sup>
4	873474	1	Key, prop shaft, Ø25mm
4	873487	1	Key, prop shaft, Ø30mm
4	873496	1	Key, prop shaft, Ø35mm

Pos	Part No	Qty	Item
4	873505	1	Key, prop shaft, Ø40mm
5	3584466	1	Propeller nut <sup>1)</sup>
6	3851994	1	Lock washer <sup>1)</sup>
7	946730	1	Hexagon screw <sup>1)</sup>
8	3581246	2	Screw <sup>2)</sup>
9	963677	3	Hex. socket screw M5x16 <sup>1,2)</sup>
10	963695	4	Hex. socket screw M6x14 <sup>1,2)</sup>
11		2	Zinc anode <sup>1,2,3)</sup>
	1161053	1	Locking fluid (10 ml) <sup>1,2)</sup>

1) Included in hub kit for S-drive. 2) Included in hub kit for shaft. 3) For part number, see chapter "Related items".

## Fixed propellers for S-drive

# Proven performance for saildrives

Our fixed propellers are exclusively designed for Volvo Penta saildrives. Manufactured using high-quality, durable aluminum alloy and with a rubber bushing in the hub, you get efficient and comfortable motoring – and at the same time secure the service life of your saildrive.

**Durable aluminum alloy**  
developed to withstand corrosion  
and cavitation damage.

**Epoxy coating** which is  
highly-resistant to abrasion.

**Rubber hub bushing**  
minimizes stress on the  
drivetrain caused by gear  
changes.

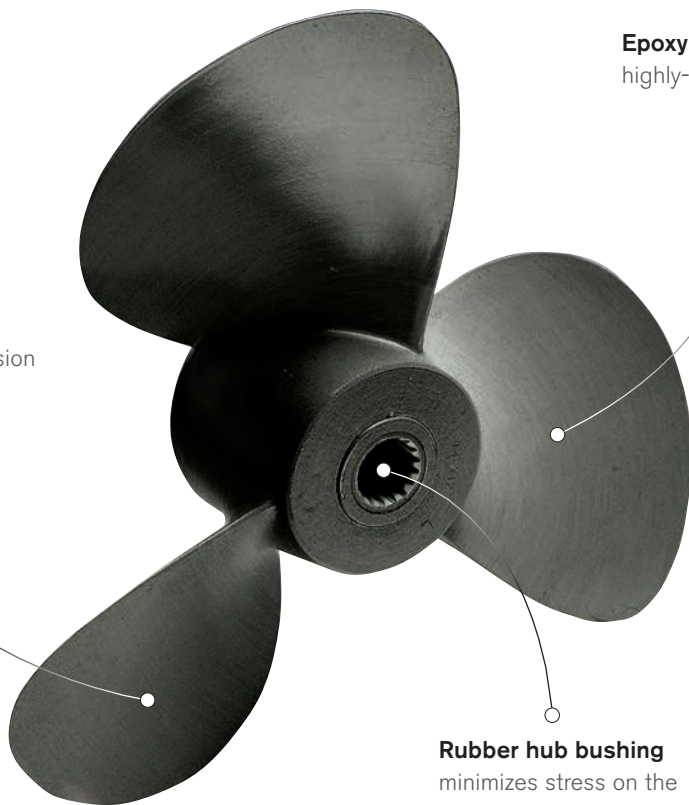

# Fixed propellers for S-drive



## 2 & 3-blade aluminum propeller

Specifically designed for your Volvo Penta saildrive to ensure efficient and comfortable motoring. Available for left-hand rotation in multiple sizes and pitches. Our 2 and 3-blade fixed propellers also include:

- Durable aluminum alloy withstands corrosion and cavitation damage.
- Shock absorbing rubber bushing to secure the service life of the drive.
- Abrasion-resistant epoxy coating.





### 2-blade aluminum propeller (110S, 120S, MS25S, 130S 150S)

Ø x PITCH		Ø x PITCH	
14 x 7	21351239	16 x 13	21351240
14 x 8	21351270	17 x 14	21351232
14 x 9	21351241	17 x 16	21351265
14 x 11	21351275	17 x 17	21353570
15 x 11	21351281	19 x 17	21351284
16 x 11	21351235		

### 2-Blade aluminum propeller (50S, 100S)

Ø x PITCH		
14 x 8	839514	MD6A
16 x 11	839191	MB10A, MD11C

### 3-blade aluminum propeller (110S, 120S, MS25S, 130S 150S)

Ø x PITCH		Ø x PITCH	
14 x 9	21381258	17 x 12	21381274
14 x 11	21381260	17 x 13	21381275
14 x 12	21381262	17 x 14	21401615
15 x 12	21381264	17 x 15	21381279
15 x 13	21381265	17 x 16	21381280
16 x 11	21381283	18 x 16	21381042

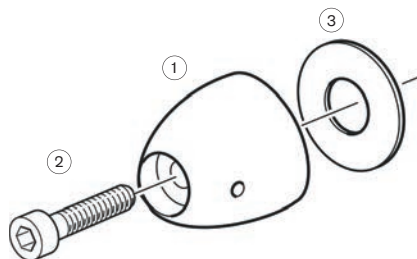

### Installation hardware, fixed propellers for S-drives 110S, 120S, MS25S, 130S, 150S

Pos	Part No	Qty	Item	Pos	Part No	Qty	Item
1	22629322		Propeller cone kit	3	850888		Plastic washer
2	851773		Screw *				

\* Included in propeller cone kit



## Related products

# Anodes for drives and propellers

Genuine Volvo Penta anodes are made to sacrifice themselves in order to protect your drive and propeller from galvanic corrosion. They are specially designed, manufactured and tested to ensure a perfect fit, reliable attachment and optimal anode protection for Volvo Penta drives and propellers.

Periodic inspection and replacement if 50% of the anode has been consumed will ensure that you get continued anode protection. When installing a new anode it is important that there is good contact between the anode and the surface to which it is connected. Read the Operator's Manual for detailed information regarding maintenance and replacing anodes for your Volvo Penta product.

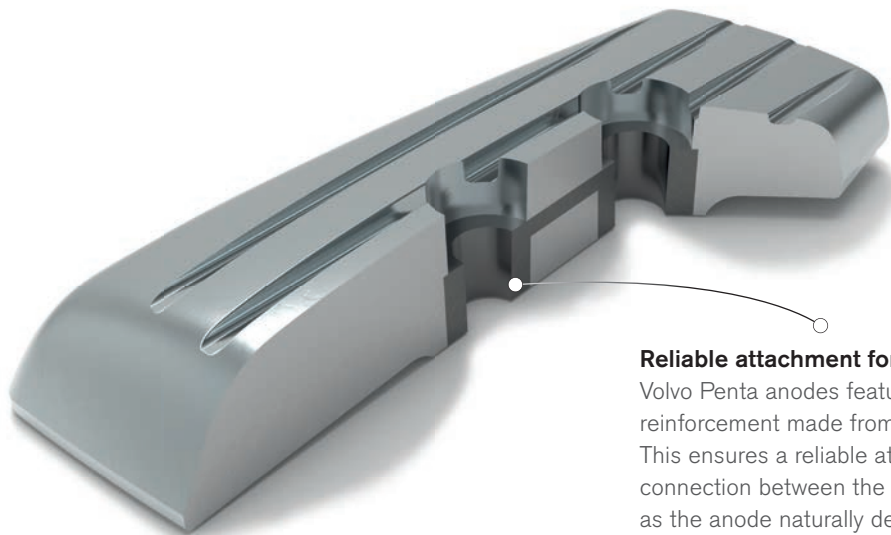

### Reliable attachment for optimal protection

Volvo Penta anodes feature, when needed, an internal reinforcement made from an alloy that does not erode. This ensures a reliable attachment and electrical connection between the anode and the drive, even as the anode naturally deteriorates.

### Choose the right anode

Here are our general recommendations how to choose the anode for the type of water where the boat is used:

- Saltwater** - Zinc
- Brackish water** - Aluminum\*
- Freshwater** - Magnesium

If zinc or aluminum anodes are left in fresh water for some time, they risk getting covered with a white oxide, which effectively stops them working. If this happens, clean the anode with emery paper to activate the anode again.

Factors like water flow, salinity, temperature, pollution levels, stray current have a major effect on the life of the anodes.

\* If aluminum anode is not available for your product, select zinc anode instead.



# Anodes for drives and propellers

## Aquamatic sterndrive – Single prop drives

Lower gear	Zinc	Aluminum	Magnesium
100 drive	875810	—	—
200 – 290, SP	875815	—	876137
Spray plate	Zinc	Aluminum	Magnesium
SX	3855411	3863193	3855412
SX-A	3888814	3888813	3888815
Transom shield	Zinc	Aluminum	Magnesium
200-280	832598	—	873179
290, SP	852835	—	873178
SX	3854130	3586461	3855610
SX-A	3888817	3888816	3888818

## Aquamatic sterndrive – Duoprop drives

Lower gear	Zinc	Aluminum	Magnesium
280, 290, DP	875821	—	876138
Spray plate	Zinc	Aluminum	Magnesium
DPS	3855411	3863193	3855412
DPS-A, DPS-B, FWD	3888814	3888813	3888815
DPH	3588746	3588748	3588750
DPR	3589875	3589876	3589877
DPX	876638	—	—
Transom shield	Zinc	Aluminum	Magnesium
280	832 598	—	873179
290, DP	852 835	—	873178
DPS	3854130	3586461	3855610
DPS-A, DPS-B, FWD	3888817	3888816	3888818
DPH, DPR	3588745	3588770	3588768
DPX	872139	—	—

## Volvo Penta IPS\*

	Part number
Lower gear anode	3593981
Transom anode IPS 1	40005875
Transom anode IPS 15, IPS 2, IPS 3	3889901
Back-up anode, Active Corrosion Protection (ACP)	21174476

\* The anode system for Volvo Penta IPS is designed to provide protection in salt-, brackish- and freshwater.

## S-Drive

Lower gear	Zinc	Aluminum	Magnesium
110S, 120S, MS25S	876286	—	876604
130S, 150S (2 piece anode)	3888305	—	3888306

## Folding propeller

S-drive	Zinc	Aluminum	Magnesium
2-blade propeller	3858399	—	3858400
3-blade propeller	3858399	—	3858400
4-blade propeller	3584442	—	3584443
Shaft	Zinc	Aluminum	Magnesium
2-blade propeller	3888491	—	3888493
3-blade propeller *	—	—	—
4-blade propeller	3584442	—	3584443

\* Use anode for shaft mounting.

# Related products

## Line cutter for Volvo Penta IPS

The line cutter is an easy to install accessory that provides additional protection in waters where it may be required. It is designed to cut through ropes, fishing lines, plastic bags and nets before they can enter between the propellers and possibly cause damage to the propeller shaft sealing.

- Cuts up ropes, fishing lines, plastic bags etc.
- Protects propeller shaft sealing.
- Easy to install using existing bolts.
- Requires no drilling.
- Adds no drag or fuel consumption.



**Note!** The line cutter is included as standard on all IPS 15 drives and on late production of IPS 1, IPS 2 and IPS 3 drives, serial numbers available in the table below.

Fits	Part No.	Qty	Diameter	Material
IPS 1 <sup>1)</sup>	21686492	1	95 mm / 3.7"	316 Stainless steel
IPS 15 <sup>2)</sup>	21913550	2	105 mm / 4.1"	316 Stainless steel
IPS 2 <sup>1)</sup>	21686494	1	120 mm / 4.7"	316 Stainless steel
IPS 3 <sup>1)</sup>	21686496	1	140 mm / 5.5"	316 Stainless steel

1) Included as standard from serial number: IPS 1 = 3940018643, IPS 2 = 3950002140, IPS 3 = 3950001773.

2) Included as standard from production start.

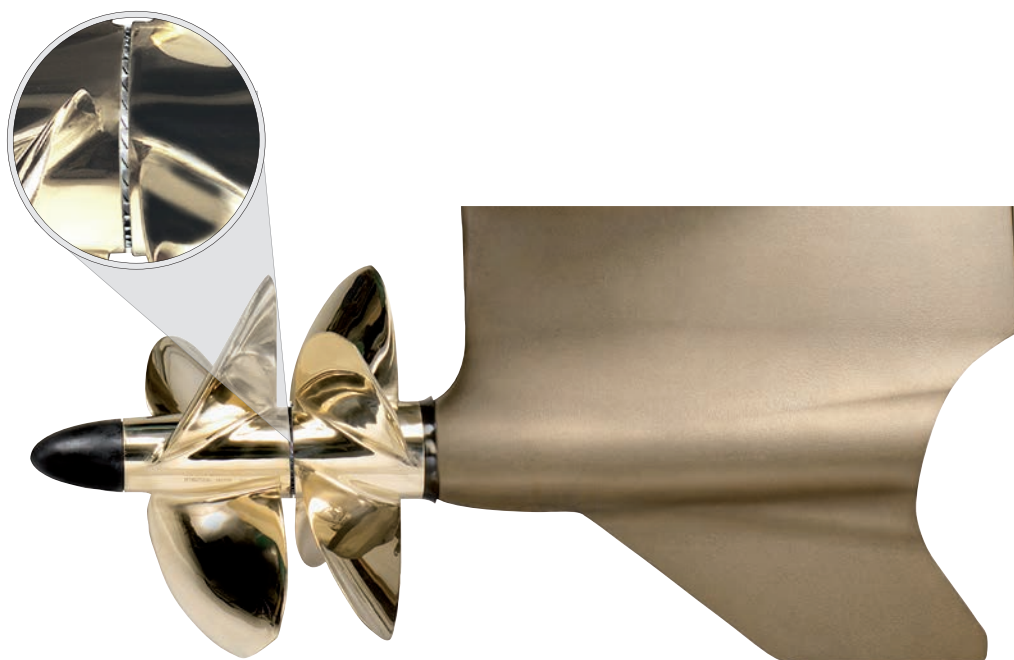

**The line cutter** is mounted to the rear propeller which creates a very efficient rotating cutting action. It is easy to install using the existing locking bolts and does not increase drag or fuel consumption.

# Related products

## Grease for propeller components

Volvo Penta water-resistant grease is designed to provide excellent adhesion, water resistance and load-carrying properties, as well as long-term protection against corrosion. It is a multi-purpose premium grease and is highly recommended for greasing propeller shafts, folding propellers and all other propeller components.

- Highly adhesive and cohesive structure.
- Superb resistance to water washout.
- Excellent corrosion protection and lubrication endurance.



Description	Quantity	Grade	Color	Part No
Tube	25g	NLGI 2	Blue	828250
Cartridge	400g	NLGI 2	Blue	22618330

## Grease it up

The propeller shaft should be cleaned and re-greased at least once a year, as well as when changing the propeller. Regular greasing will prevent the propeller from sticking to the propeller shaft. Refer to the operators manual for recommended intervals.







Please contact your local Volvo Penta dealer for further information. Please note that products illustrated may differ from production models. Not all models and accessories are available in all markets, and standard equipment may vary between different markets. Every effort has been made to ensure that facts and figures are correct at the time of publication. However, Volvo Penta reserves the right to make changes without prior notice at any time.

**VOLVO  
PENTA**

[www.volvopenta.com](http://www.volvopenta.com)